

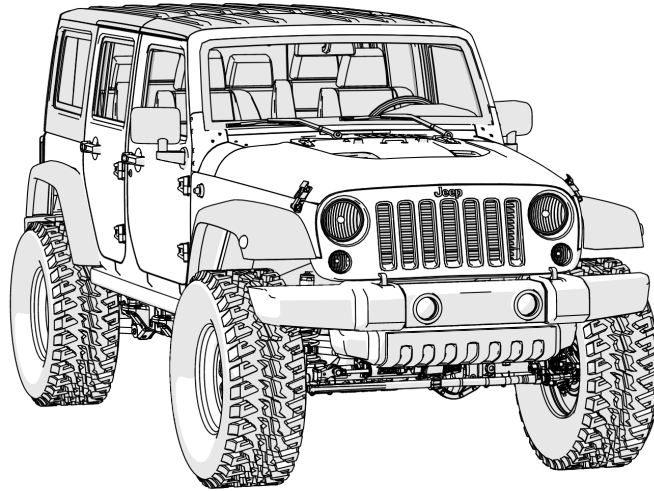

07-17 JK 3" Suspension Lift Kit

Instructions

www.teraflex.com



Important Notes:

Prior to beginning this installation read the instructions to familiarize yourself with the required steps and evaluate if you are experienced and capable to personally perform these modifications. A factory service manual should be used in conjunction with these installation instructions.



Refer to the parts list to ensure that all necessary components and hardware has been included. If any parts are missing please contact your local TeraFlex dealer for assistance.

***The front and rear bumpstop pads provided in this kit are intended to be used with Falcon Shocks. If installing another shock, the point at which the suspension bottoms-out will need to be checked to ensure that the shocks and/or mounts are not damaged due to the shock reaching it's minimum length before the pads can hit the bumpstops.**

****Stock brake line will be used and are long enough for a 3" lift. Steel braided brake hoses are available, but are not included in kit. (Part # 4353310 Front Brake lines, 4350310 Rear Brake Lines)**

Tools Needed

- Ratchets - 1/4" and 1/2"
- 1/4" Drive Socket Set - 5/16", 10mm, 7/16"
- 1/2" Drive Swivel/Wobbly Sockets - 18mm, 21mm, 3/4"
- 1/2" Drive Socket Set - 18mm, 21mm, 3/4"
- 1/2" Extension - 12" Long
- Allen Wrench - 3/16", 5mm
- End Wrench Set - 7/16", 1/2", 9/16", 1-1/8", 13mm, 15mm, 16mm, 18mm, 19mm, 21mm
- Drill and Drill Bit Set - 1/8", 1/4", 3/8", 1/2" or step drill bit
- Reciprocating Saw and Bi-metal Blade
- Wire Cutters
- Locking Plyers
- Large Pry Bar and Heel Pry Bar
- Air Hammer (or Hammer)
- Chisel
- Measuring Tape
- Blue Loctite

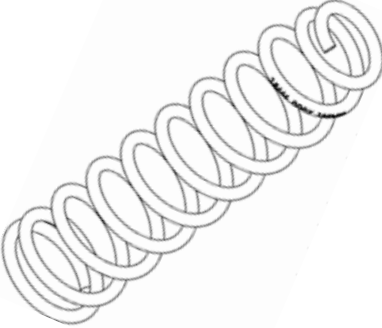
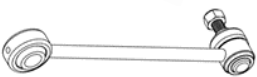
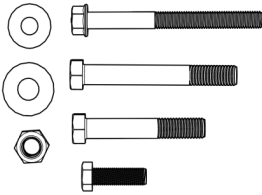
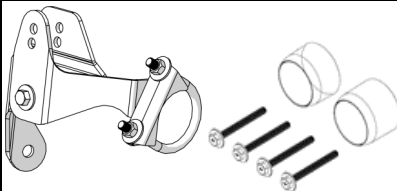
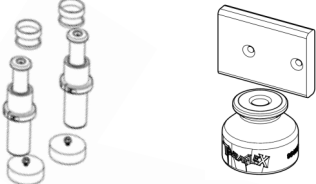
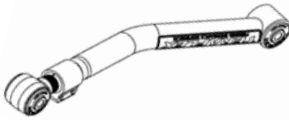
									
		Description	Item #	4DR	2DR	4DR	2DR	4DR	2DR
Spring Box Components		Front	1863200	2					
		Rear	1864200	2					
		Front	1861100		2				
		Rear	1862200		2				
		Front	1853200			2		2	
		Rear	1854200			2		2	
		Front	1853100				2		2
		Rear	1854100				2		2
		Swaybar Link, Front Quick Disconnect	753005	2	2	2	2	2	2
		Rear Swaybar Link	754500	2	2	2	2	2	2
		Rear Trackbar Bracket Hardware	600080	1	1	1	1	1	1
		Quick Disconnect Hardware	600093	1	1	1	1	1	1
		3" Lift Kit Hardware	610074	1	1	1	1	1	1
		FlexArm Cam Bolt Eliminating Kit	4951700	1	1	1	1	1	1
	Rear Trackbar Bracket	954776	1	1	1	1	1	1	
	Brake Line Anchor, Pair, 5" Long	1101255	1	1	1	1	1	1	
	Exhaust Spacer	2610000	1	1	1	1	1	1	
Other Boxed Kits		SpeedBump Kit +Bumpstops F/R	1958250	1	1	1	1		
		Bumpstop Extension Kit F/R	1954620						
		Sport Arm / Speed Bump Kit F/R	1958255					1	1
		4 Arm Sport Control Arm Kit	1254000						
		Alpine Adjustable Control Arm Kit	1415610	1	1	1	1		
	Other Kits	Front Monster Trackbar Kit	1753418	1	1	1	1	1	1
		Front / Rear Limit Strap Kit	4853100						

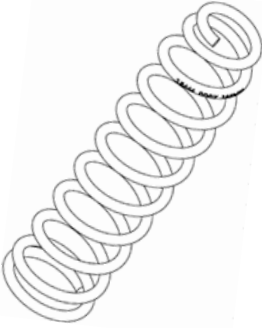
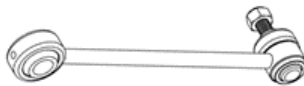
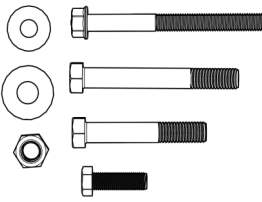
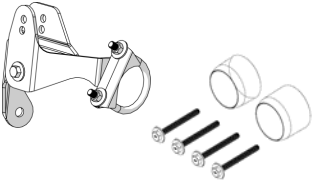
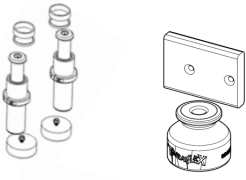
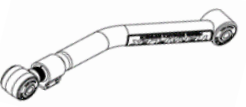
			3" W/4 Flexarms		3" Base		
			4DR	2DR	4DR	2DR	
			Description	Item #			
Spring Box Components		Front	1863200				
		Rear	1864200				
		Front	1861100				
		Rear	1862200				
		Front	1853200	2		2	
		Rear	1854200	2		2	
		Front	1853100		2		2
		Rear	1854100		2		2
		Swaybar Link, Front Quick Disconnect	753005	2	2	2	2
		Rear Swaybar Link	754500	2	2	2	2
		Rear Trackbar Bracket Hardware	600080	1	1	1	1
		Quick Disconnect Hardware	600093	1	1	1	1
		3" Lift Kit Hardware	610074	1	1	1	1
		FlexArm Cam Bolt Eliminating Kit	4951700	1	1	1	1
	Rear Trackbar Bracket	954776	1	1	1	1	
	Brake Line Anchor, Pair, 5" Long	1101255	1	1	1	1	
	Exhaust Spacer	2610000	1	1	1	1	
Other Boxed Kits		SpeedBump Kit +Bumpstops F/R	1958250				
		Bumpstop Extension Kit F/R	1954620	1	1	1	1
		Sport Arm / Speed Bump Kit F/R	1958255				
		4 Arm Sport Control Arm Kit	1254000	1	1		
		Alpine Adjustable Control Arm Kit	1415610				
	Other Kits	Front Monster Trackbar Kit	1753418	1	1		
		Front / Rear Limit Strap Kit	4853100				

FRONT REMOVAL

Lift the vehicle and support it by the frame.
 Remove wheels and support the front axle.
 Loosen all the control arms bolts (front and rear), but do not remove.
 Remove the exhaust skid plate/cross member using an 18mm. The exhaust skid plate will not be reused.
 Remove the front driveline at the axle and support it up out of the way with a bungee or strap (15mm).



1

Remove the front track bar (21mm) from the axle end and support it up out of the way.

Loosen the nut on the drag link at the axle with a 21mm (see illustration below). Use an air hammer or hammer to tap on the steering knuckle to free the ball joint. Once free remove the nut and support drag link up out of the way.

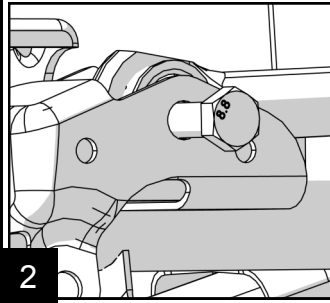

2

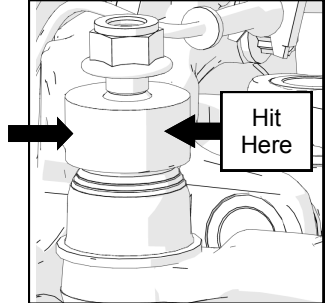
**FRONT SHOCK REMOVAL**

Use an 18mm for lower bolt and a 16mm for upper nut.

NOTE: On 2012+ JK's, the passenger side upper shock mount is not accessible due to the battery tray. Use a pair of diagonal pliers and cut/break out enough of the thin plastic to gain access to top nut.

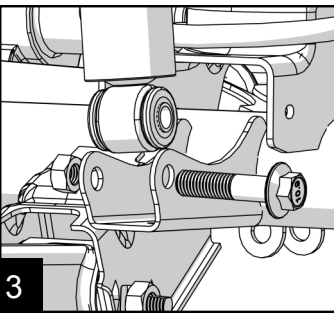

3

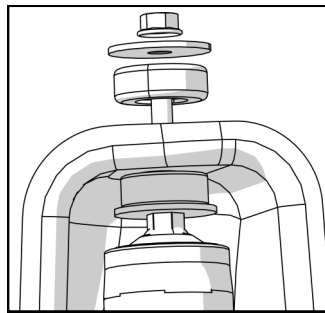
**FRONT SWAYBAR LINK REMOVAL**

Remove both front swaybar links with an 18mm.

NOTE: 2011+ JK's have brake line retainers located under the spring perches. Use a 10mm to remove the retainer bracket from the axle.

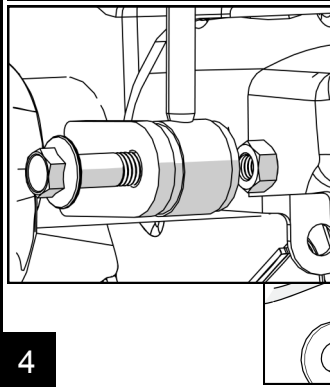

4

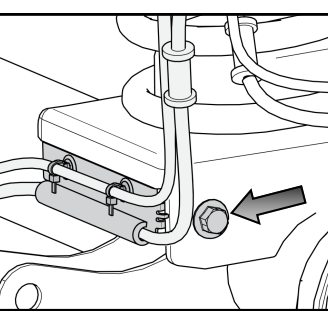
**FRONT SPRING REMOVAL**

Unclip the ABS lines, and extend the axle breather tube by sliding the tube retainer clip down the shock tower 3". This will prevent the tube from being pulled tight during full axle droop. Also remove Locker Actuators and Sensor Harnesses if your vehicle is equipped with them.
 Lower the front axle and remove the springs. Be sure to check for any lines that can be pulled or damaged.

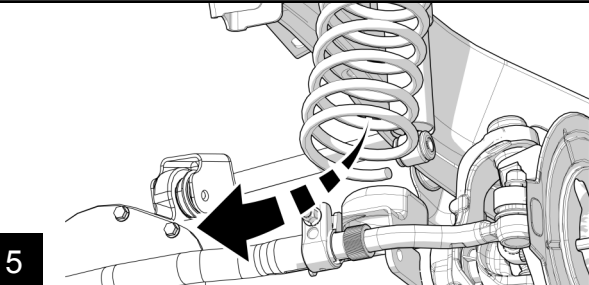

5

FRONT INSTALLATION

NOTE: When install the front coil springs, do the drivers side first, followed by the passenger side. Rotate the spring until they are fully seated

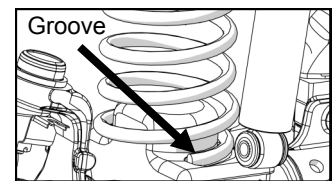

OUTBACK, CT3, SPORT S/T3, AND MOPAR S/T3 KITS: Refer to the Front Upper and Lower sections of the Speedbump Instructions #999292
3" +4FLEXARMS, AND 3" BASE KITS: Refer to Front section of Bump Stop Extension Instructions #999300

6

FRONT SHOCKS

If using Falcon Shocks follow instruction included with them to install the fronts now. If using other shocks install them now. **Torque the top nut to 20 ft-lbs (27 N-m).** Leave lower bolt loose for the brake line anchor install.

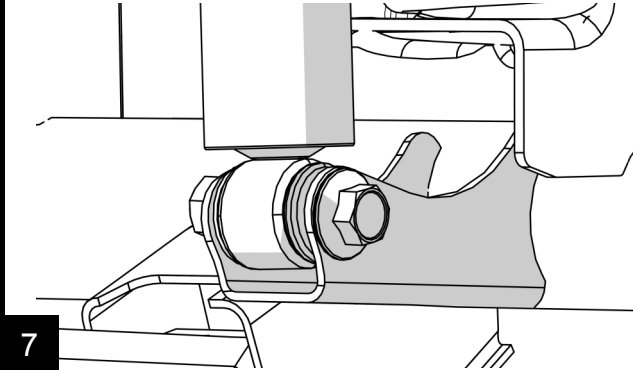

7

QUICK DISCONNECT SWAY BAR LINKS

Insert 3/4" QD stud into axle bracket (as shown). Place 1/2" washer and nylock nut onto the QD stud.

NOTE: The stud is stainless steel and the threads are soft. Take care to not over tighten the nut.

Torque nylock nut to 75 ft-lbs.

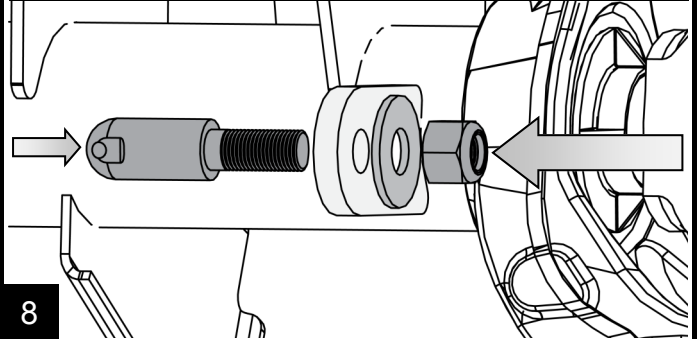

8

Install the swivel stud of the quick disconnect sway bar link into the sway bar. Place 7/16" washer and M12 nylock nut onto the stud. Use a 6mm allen to hold the stud, tighten down the nut with a 18mm wrench. **Torque nylock nut to 75 ft-lbs.**

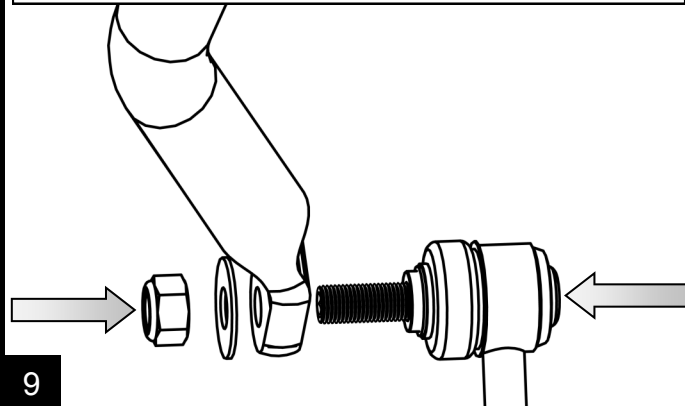

9

Slide the lower end of sway bar link onto the stud. Place washer 3801 on stud and insert Bow Tie Pin.

NOTE: This should be a tight fit for better sway bar function. Applying a bit of grease to the stud and bushing will help with install.

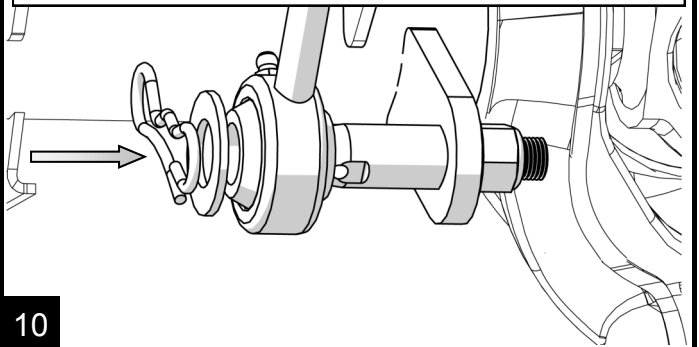

10

Remove the front body mount nut from the stud and slide on (600277) retaining bracket. Next insert 5/8" QD stud into retaining bracket and install 3/8" jam nut.

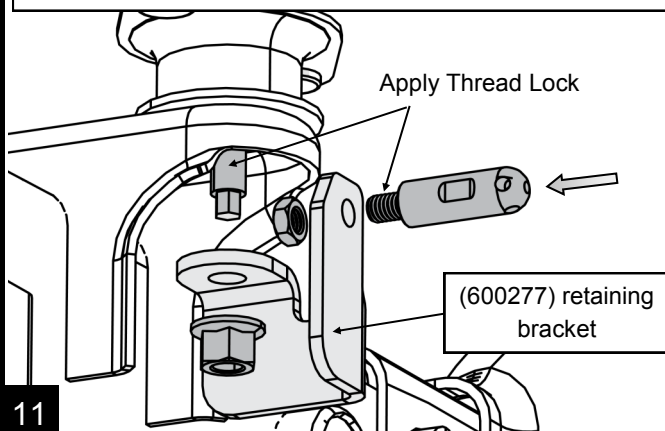

11

Torque the body mount to 80 ft-lb and jam nut to 75 ft-lb.

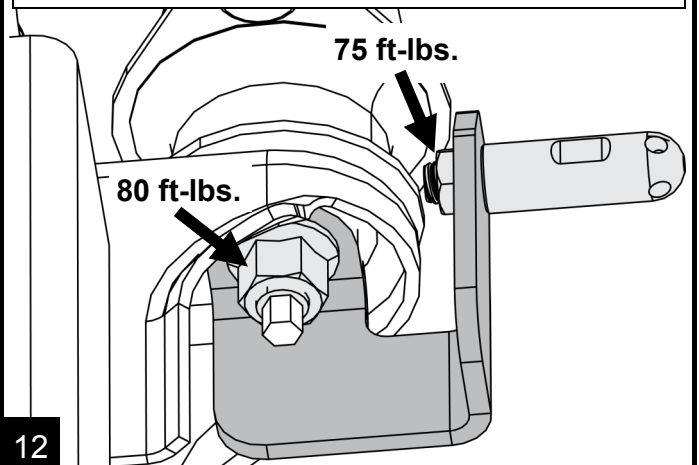

12

FRONT CONTROL ARMS

OUTBACK, AND CT3 KITS: Refer to the Front Upper and Lower Control Arm sections of the Alpine Short Control Arm Instructions #999253

SPORT S/T3, MOPAR S/T3, AND 3" +4FLEXARMS KITS: Refer to the Front Lower section of Fixed Length Control Arms Instructions #999173.

FRONT TRACK BAR

OUTBACK, CT3, SPORT S/T3, MOPAR S/T3, AND 3" +4FLEXARMS KITS: Refer to the Front Track Bar Instructions #999044

13

3" BASE KIT: Reinstall the track bar into the axle bracket.

Tech Tip: If the hole does not line up then the axle side can be installed once the Jeep is on the ground. Have someone move the steering wheel, this will move the Jeep relative to the axle and help the holes to line up. Tighten bolts finger tight. **Once the Jeep is on the ground, torque both bolts to 125 ft-lbs.**

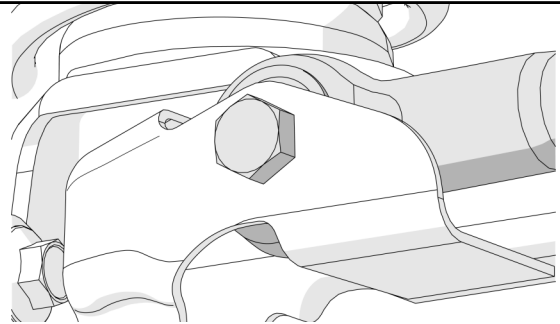

14

INSTALLATION OF BRAKE LINE ANCHOR

Remove stock brake line anchor from brake lines using a pair of locking pliers.

Use some cable ties to route the ABS and brake lines together so they are uniform and equal.

NOTE: Zip ties provided in the kit are for mounting the lines to the Anchor. Extra cable ties can be picked up from just about any hardware store.

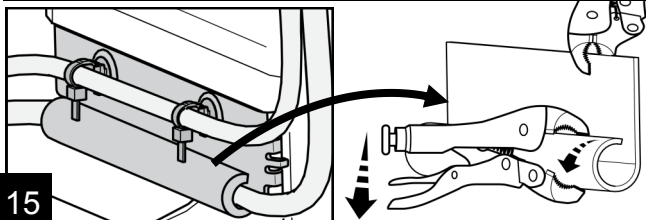

15

The Rubber Brake Line Anchor can be mounted on the inside or outside of the bottom shock mount bolt.

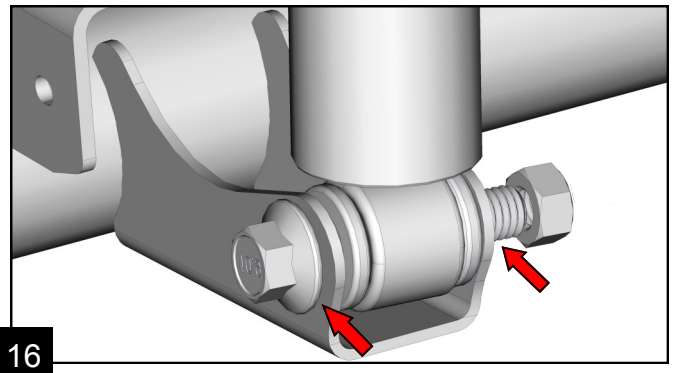

16

If there is plenty of length to your lines then mount the anchor on the inside, directly under the nut. If your lines are stiff or length is an issue it might be better to install the anchor on the out side of the shock mount.

NOTE: Use a large screwdriver or pry bar under the shock to help install shock mount bolt.

Do not tighten the shock mount bolt

Once the anchor is installed then install the ABS line into the anchor followed by the brake line. (see picture)

Loosely install a cable tie. Inspect the brake lines and adjust positions as needed.

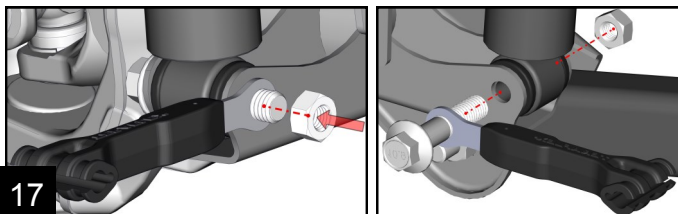

17

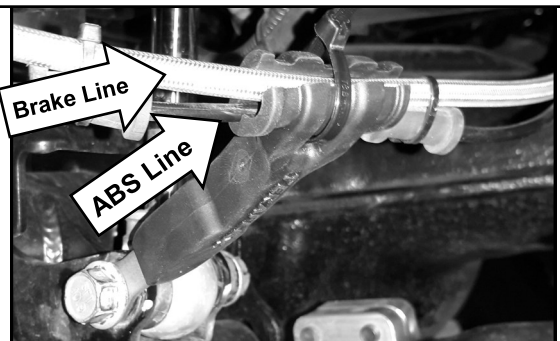

18

We installed the lines so that the anchor was pulled slightly toward the tire when it was turned out. This was to help the lines stay clear of the tire when it is turned the opposite way. Loosely install the rest of the cable ties. **Slightly tighten** the shock bolt.

Test the position of the lines and anchor by turning the wheel from lock to lock and articulating the axle. With the shock bolt only snug the anchor can be rotated to help find the best angle.

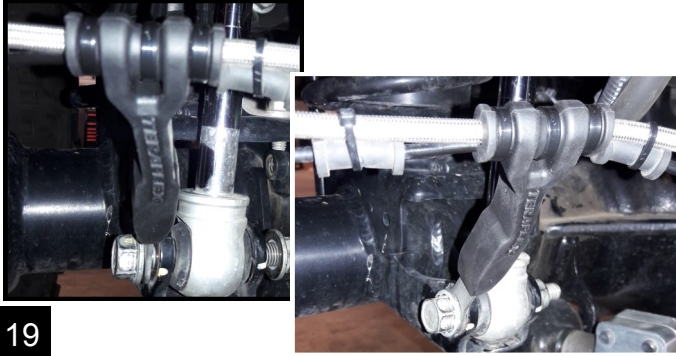

19

20

IMPORTANT NOTE! **Watch the anchor for clearance from the shock body.**

Once the best position is found, that keeps the brake lines safe from snags or damage, tighten and trim the cable ties and torque the shock bolts. 56 ft. lbs. (76Nm)

FRONT DRIVE LINE

Reinstall the front drive line. Apply thread locker to the bolts and torque to 15 ft-lbs. (20Nm)

Do not torque the trackbar bolts until the vehicle is lowered to the ground.

Final torqueing of all suspension and trackbar bolts will take place once the Jeep is on the ground at ride height.

21

22

EXHAUST SPACER INSTALL

NOTE: If you are installing this lift on a 2012 or newer Jeep JK, you must install the exhaust spacer kit. If you are installing this kit on a 2007-2011 Jeep JK, please proceed to Page 9 Step 1.

Using a 13mm, remove the four exhaust flange bolts at the left and right crossover pipe collectors.

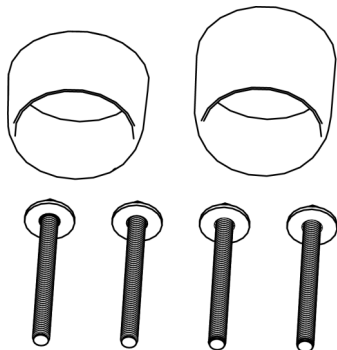

23

24

Loosen the Y-pipe clamp that joins the front and rear sections of pipe. This will allow the exhaust to slide together to maintain correct positioning of the exhaust.



25

Using a chisel, remove the spot welded indexing stop on the intermediate pipe. This will allow the intermediate pipe to slide into the y-pipe to provide added clearance.

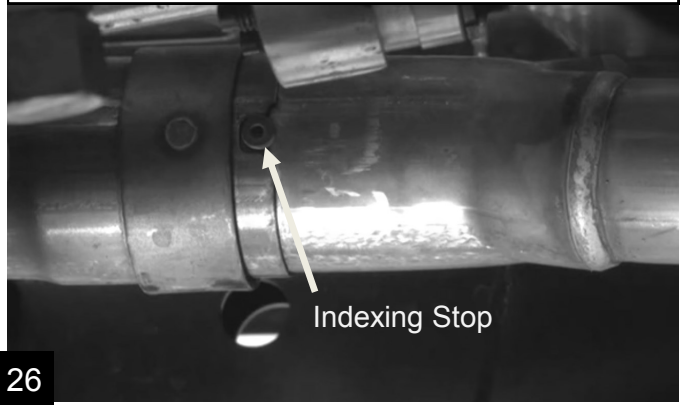

26

Place a pry bar between the front skid bar and the driver side rear pipe flange; separate the exhaust and insert the spacers between the flanges. The longer spacer is used on the passenger side.

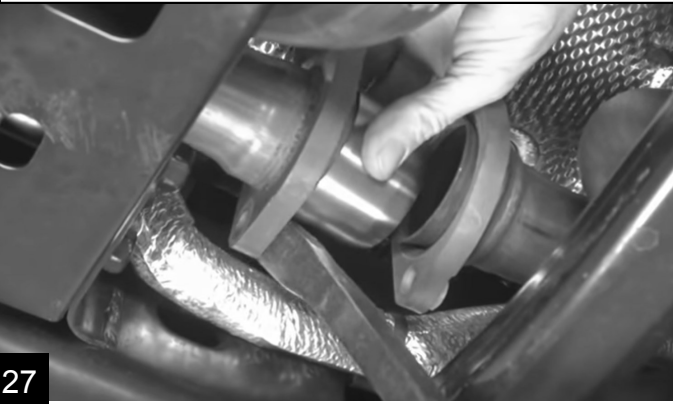

27

Install the supplied bolts into the exhaust flanges and tighten evenly. Make sure the exhaust pipes are still properly aligned and the spacers are straight. Check the exhaust system for clearance and retighten the Y-pipe clamp .



28

REAR REMOVAL

Support the rear axle.

Remove the rear shocks and trackbar at the axle.

Remove rear swaybar links.

Remove the rear driveline at the axle and support it up out of the way with a bungee or a strap (15mm).

Release the axle breather tube from the upper retaining clip on the underside of the Jeep body.

Release the ABS line from the two retaining clips on the axle (on each side).

For Rubicon owners release the plastic retainer for the locker wiring harness.

1

BRAKE CABLES AND LINES

With a 10mm remove the park brake cable bracket from the bottom of the Jeep. Fully remove the park brake cables from the hanger bracket and discard the bracket.

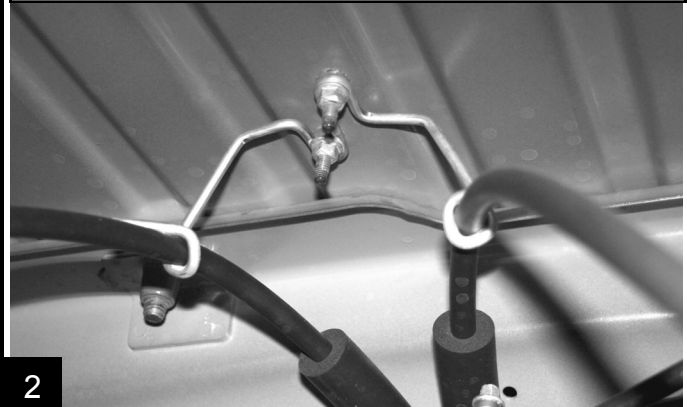

2

Remove the brake line mount from the frame with a 10mm.



3

REAR SPRINGS

Carefully lower the axle enough to remove the spring. Be sure to watch the ABS, brake lines and breather tubes for overextension. Remove the old spring.

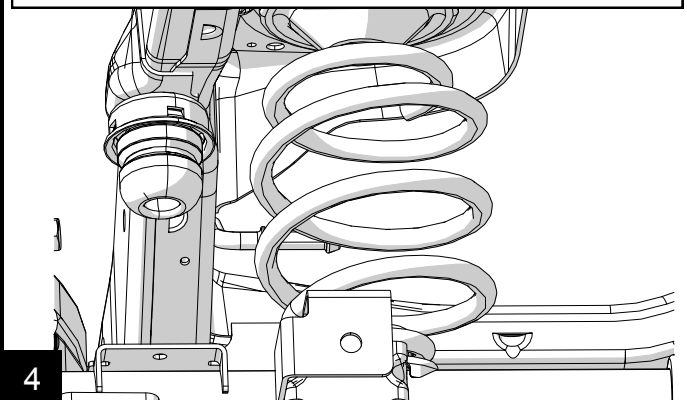

4

OUTBACK, AND CT3 KITS: Refer to the Rear Upper and Lower Control Arm sections of the Alpine Short Control Arm Instructions #999253

SPORT S/T3, MOPAR S/T3, AND 3" +4FLEXARMS KITS: Refer to the Rear Upper section of Fixed Length Control Arm Instructions #999173

5

REAR INSTALL - SPRINGS AND SHOCKS

Install the factory rear upper spring isolators and the new rear coil springs. **NOTE:** The upper pigtail end needs to be turned all the way to the rear of the Jeep.

KITS WITH FALCON SHOCKS: Refer to Falcon Shock Instructions. **OTHER SHOCKS:** Install with factory hardware. **Torque upper bolts to 37 ft-lbs (50 Nm) and lower bolts to 56 ft-lbs (76 Nm).**

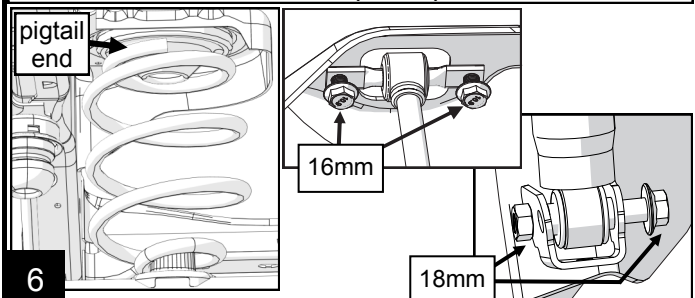

6

REAR LOWER SPRING RETAINER

Place the retainer on the lower spring pad.

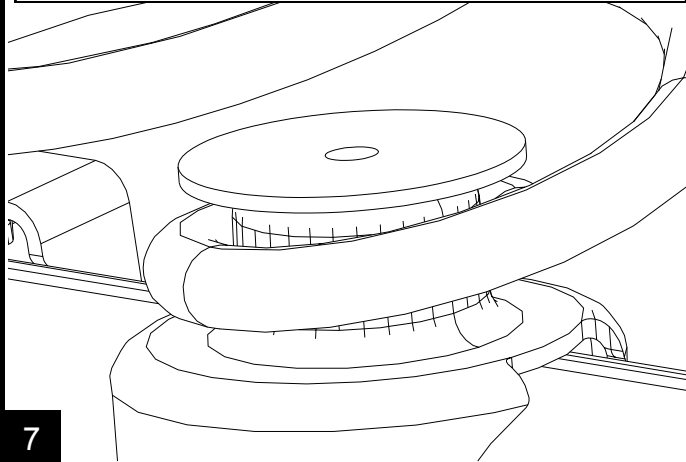

7

Install the 3/8" bolt and lock washer through the spring retainer and spring pad.

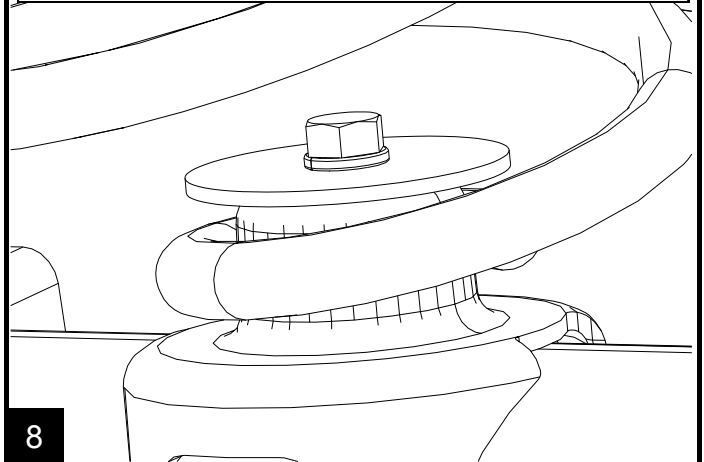

8

Place a nut into the provided tool. Slide the tool underneath the spring pad from the front of the axle and thread the bolt into the nut.

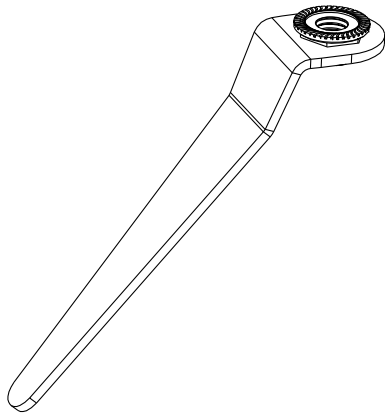

9

Torque the bolts to 30 ft-lbs (41 Nm)

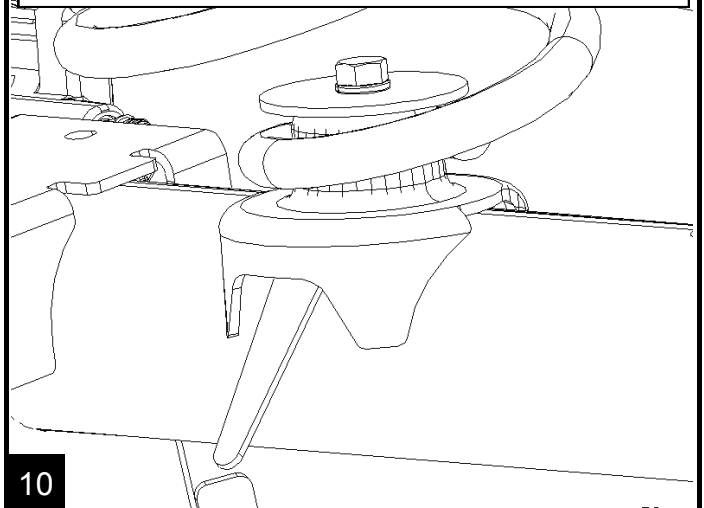

10

REAR UPPER SPRING RETAINER

Locate the factory hole at the frame side coil bucket.



11

Using the supplied hardware, install the coil retainer in between the top to coils. Using a 3/4 socket and wrench **torque the bolt to 50 Ft-lbs**



12

MOPAR S/T3 KIT: Refer to the JK Limiting Straps Instructions #999050

13

REAR TRACKBAR BRACKET

Locate the trackbar bracket and hardware kit (600080). The lower ear of the trackbar bracket, and the driver lower control arm share the same bolt. They will need to be installed together.

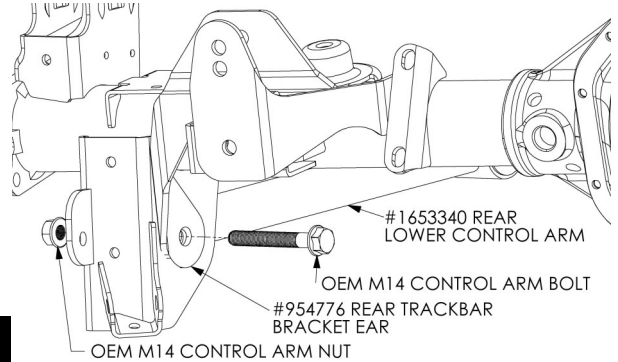

14

Position the trackbar bracket for install and swing the lower control arms up into place and insert the lower control arm bolt. Do not tighten. Install the trackbar bracket sleeve spacer and #242 bolt, #37 washer and #214 nut.

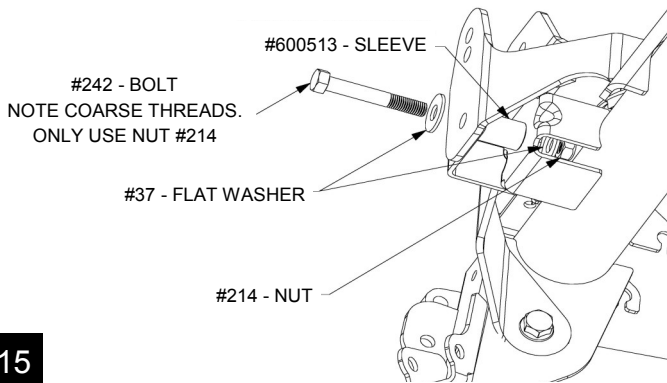

15

Install the U-bolt nuts and washers. **Torque the U-bolt lock nuts to 45 ft-lbs**
Torque: 1/2" bracket bolt with the spacer to 75 ft-lbs

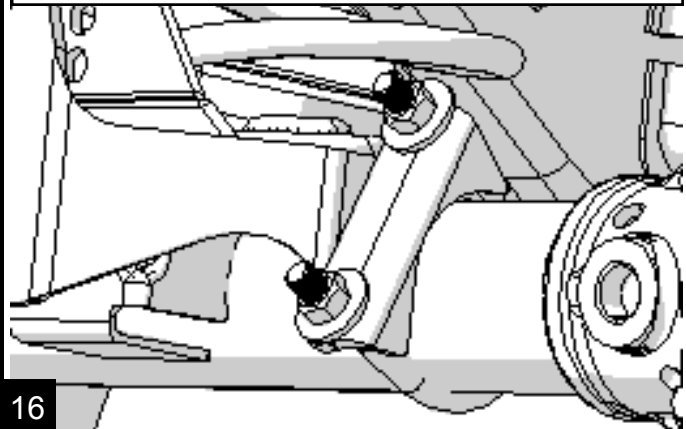

16

Install the rear trackbar using the upper holes in bracket using the factory hardware. **Do not tighten track bar bolts.** If getting the bolt holes to line up is difficult you can wait until Jeep is on the ground, then have a helper push the Jeep from the side to line up holes. **Once Jeep is back on the ground torque bolt to 125 ft-lbs.**

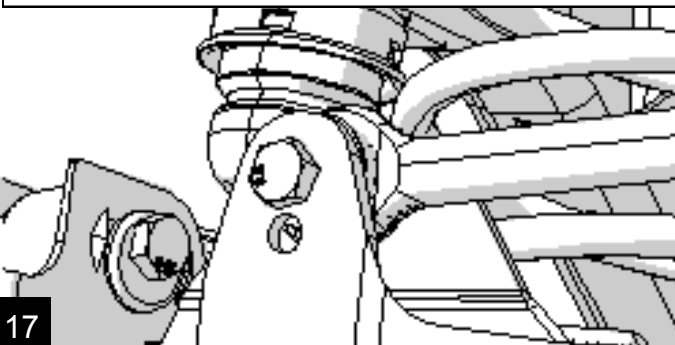

17

REAR BRAKE LINE EXTENSION BRACKETS
Locate the brake line extensions and hardware. Use the supplied 1/4" hardware to attach the factory bracket to the new extension.

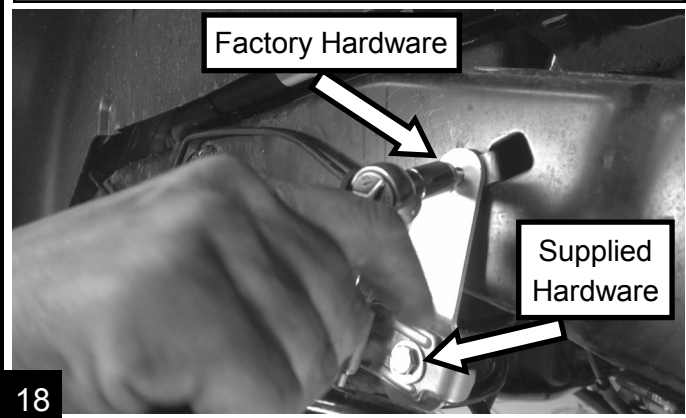

18

IMPORTANT NOTE! It is imperative at this time to cycle the swaybar and check for proper clearance between the swaybar and the brake line. Make the necessary bends in the brake line and bracket to clear the swaybar link as it goes through its range of travel.



19

Install the new swaybar link with the swivel stud end at the top and the mounting stud pointing towards the frame. Torque upper and lower to 75 ft-lbs (102 Nm).

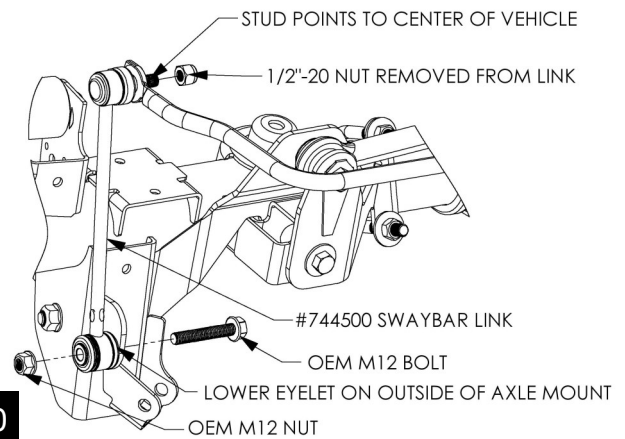

20

OUTBACK, CT3, SPORT S/T3, AND MOPAR S/T3 KITS: Refer to Rear Upper and Lower sections of Speedbump Instruction #999292

3" +4FLEXARMS, AND 3" BASE KITS: Refer to the Rear section of Bumpstop Extension Instruction #999300

21

RELOCATE REAR BREATHER TUBE

Secure the axle breather tube to the cross member.



22

RELOCATE EVAP CANISTER

NOTE: 2012+ 4-Door Wrangler must relocate the EVAP canister for proper driveline clearance at full suspension articulation. 2007-2011 4-Door and all 2-Door JK's skip to step 27.

Locate the EVAP canister and skid plate located under the vehicle next to the rear driveline. Use a 16mm to remove the two front bolts of the EVAP canister. Loosen the rear bolt, but do not remove.

23

Mark a centerline of the existing holes (labeled Line A). Mark a spot about half way between the two existing holes (labeled Point B) and one 50mm to the left of Point B. (labeled Point C). Center punch and drill a 1/2" hole at Points B and C. Use a small block of wood as a spacer behind the bracket for drilling.

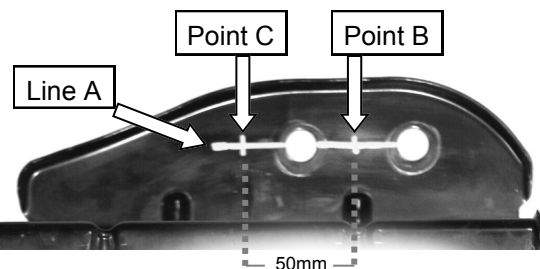

24

Remove the wood, rotate the canister and skid plate. Reinstall using the two new mounting holes. Torque all three bolts to 10 ft-lbs (14 Nm)

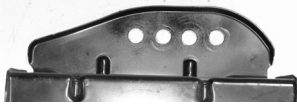

Results after drilling.

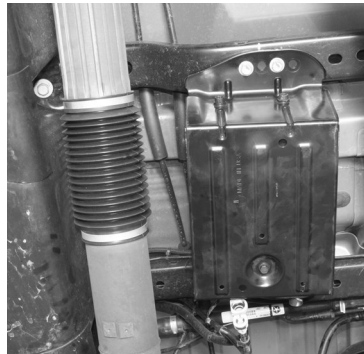

25

Reinstall the rear drive line. Apply thread locker to the bolts and torque to 15 ft-lbs. (20Nm).

NOTE: The rear drive line can be rotated, if desired, to get the boot out of harms way.

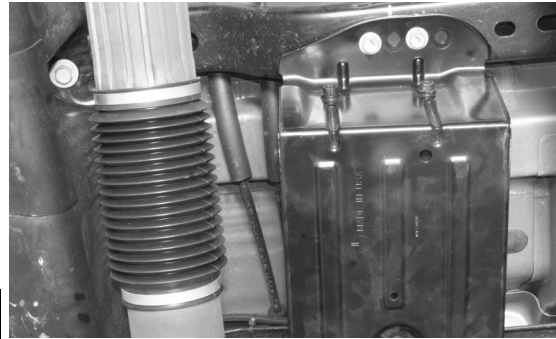

26

TORQUE CONTROL ARMS AND TRACK BAR

Reinstall the wheels and tires. Torque lug nuts to Factory Spec and *lower the Jeep to the ground*.

With the Jeep on the ground, torque control arm, track bars, track bar brackets and all other bolts that have not been tightened. This will ensure that the bushing load is in a neutral position throughout the Jeep.

Front Upper Control Arms	75ft-lbs	102Nm
Rear Upper Control Arms	125ft-lbs	169Nm
Front and Rear Lower	125ft-lbs	169Nm
Front and Rear Trackbars	125ft-lbs	169Nm

27

STRAIGHTENING THE STEERING

Before test driving the Jeep, do a quick visual check to make sure the tires are straight when the steering wheel is centered. Adjust the drag link as needed to center the steering wheel. Drive a short distance down a straight road and, if necessary, readjust the steering wheel to center. Torque the draglink adjusting sleeve to 26 ft-lbs (35 Nm).

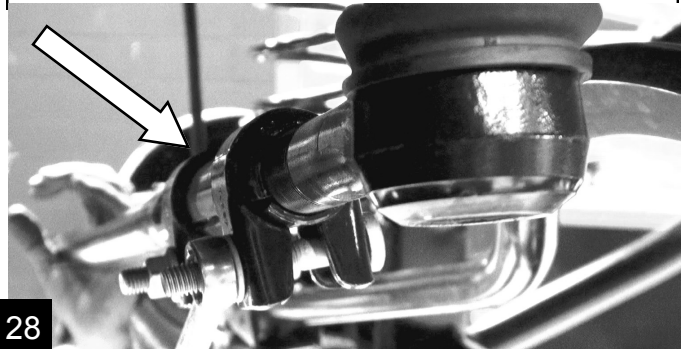

28

Install is now Complete!

Congratulations! Your hard work, unprecedented dedication, and extreme attention to detail have earned you a very sweet ride. Go enjoy a day or two in the back country. After all, you earned it.

Perform a final check of the suspension components and hardware torque.

Maintenance Note: After the first 500 miles and every 3,000 miles after that, re-torque all the suspension components and bolts.

29

PRODUCT INFORMATION

MAINTENANCE INFORMATION:

It is the buyer's responsibility to have all suspension, drivetrain, steering, and other components checked for proper tightness and torque after the first 100 miles and every 3000 miles after that.

NOTICE TO INSTALLER:

The enclosed "Warning to Driver" sticker must be installed in the vehicle in driver's view. This sticker is to act as a constant safety reminder when operating the vehicle. It is your responsibility as the equipment installer to install the provided sticker and to forward the product instructions to the vehicle's owner for review. If a "Warning to Driver" sticker or product installation guide were not included in the kit, FREE replacement stickers and instructions are available by request. It is the installer's duty to ensure a safe and controllable vehicle after the modifications have been performed.

WARNING:

Neither the seller nor the manufacturer will be liable for any loss, damage, or injury directly or indirectly arising from the use of or inability to determine the use of these products. Before using, the user shall determine the suitability of the products for its intended use, and the user shall assume all responsibility and risk in connection therewith.

WARNING TO DRIVER:

This vehicle has been modified to enhance off road performance and has unique handling characteristics. Use in harsh environments can cause extreme stress on the components. Vehicle should be inspected after being off road to make sure that all the components are in working order and safe to travel on the highway. All fasteners should be checked so that they are at the correct torque specifications as the vibration and stresses from off roading may cause critical fasteners to work loose. Extra care should be taken to inspect the critical components, steering, and brake systems. During each oil change components such as arms, tie rod ends, etc should be greased and checked for excessive wear. Any worn components should be replaced. When returning to the pavement always set or restore tire air pressure to the factory recommendation and connect or engage any disabled sway bar mechanisms. Because of the higher center of gravity and larger tires, this vehicle handles and reacts differently than many passenger cars, both on and off road. You must drive it safely! Extreme care should be taken to prevent vehicle rollover or loss of control, which can result in serious injury or death. Avoid sudden sharp turns or abrupt maneuvers. Generally, braking performance and capabilities are decreased when significantly larger/heavier tires are used, especially when used in combination with transfer case low-range reduction kits. Take this into consideration while driving. Do not add, alter or fabricate any factory or aftermarket parts to increase vehicle height over the intended height of the TeraFlex product purchased. Mixing component brand is not recommended. TeraFlex Inc. will not be responsible for any altered product or any improper installation or use of our products. We will be happy to answer any questions concerning the design, function, and correct use of our products. It is ultimately the buyer's responsibility to have all bolts/nuts checked for tightness after the first 100 miles and then every 3000 miles. Wheel alignment, steering system, suspension and drive line systems must be inspected by a qualified professional mechanic at least every 3000 miles.

TERAFLEX PRODUCT WARRANTY:

TeraFlex Inc. warrants TeraFlex Suspension products to the original retail purchaser to be free of defects in material and workmanship for as long as the original purchaser owns the vehicle on which products were originally installed.

Failure to complete regular maintenance (grease every 3000 miles) on TeraFlex FlexArms will void this warranty. All other conditions of the standard TeraFlex product warranty apply.

All TeraLow products are covered by the TeraFlex two (2) year warranty to be free of defects in material and workmanship for two years from date purchased.

TeraFlex axles are covered by a 12-month warranty to be free of defects in materials and workmanship.

This warranty does not cover or include product finish, improperly installed or applied products, improperly maintained products, products or components used for racing or competition or damage due to abuse or neglect, products that fail due to the use of larger tire and wheel combinations.

All returns must be accompanied by an original invoice. It is the customer's responsibility to remove the product from the vehicle. Shipping charges are the responsibility of the customer. TeraFlex Inc. will pay the return freight if the product meets the terms of warranty.

This warranty is for the replacement or repair of defective TeraFlex products only and does not include freight charges, labor charges for removal of or installation of TeraFlex or related products or components, costs incurred due to down time of the vehicle, or lost profits due to vehicle down time.

A returned goods authorization number (RGA#) must accompany any returned products. For more information please contact a TeraFlex customer service representative.

COPYRIGHT

©Copyright 2014. All rights reserved, TeraFlex Inc. Reproduction of this catalog and/or any of its contents without written permission is strictly prohibited.

TeraFlex® is a registered trademark of TeraFlex Inc. All trade names and logos including but not limited to TeraFlex, FlexArms, RockGuard, Monster, and LCG are protected by law and duplication of trade names and/or logos are strictly prohibited.

TeraFlex Inc. reserves the right to update, discontinue, redesign, modify finish, part number or component build parts if deemed necessary without written notice.

TeraFlex Inc., and any associated dealers are not responsible for misprints or typographical errors that may have inadvertently been made within this instruction sheet.

Jeep® and the Jeep® grill are registered trademarks of Fiat Chrysler Automobiles N.V., and have no affiliation with TeraFlex Inc.

TERAFLEX, Inc.
5680 West Dannon Way
West Jordan, Utah 84081
Phone/801.713.3314
Fax/801.713.2313
www.teraflex.com